

Küchen
kitchen | wardrobe | living

Product Care Guide
Version 1.0 | Feb 2023

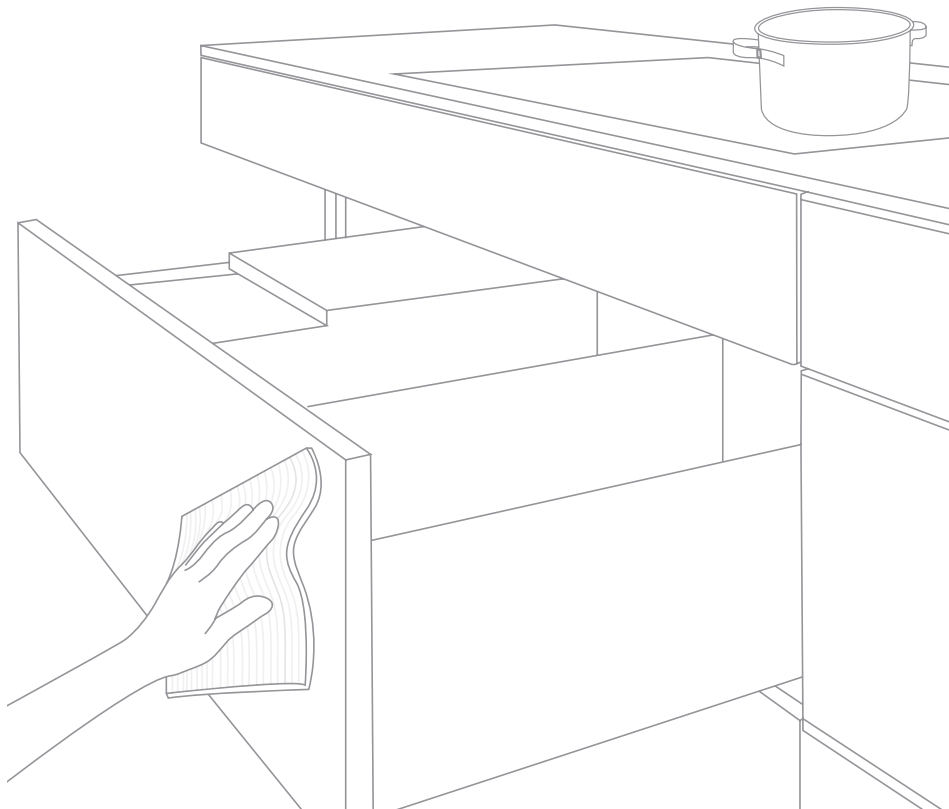

- 1.** It is recommended to clean kitchen surfaces with a clean and soft cloth that does not have any stitches on the inside to avoid spreading any dirt or bacteria.



- 2.** Clean and wipe kitchen cabinets using mild cleaning agents to prevent damage.



3. Avoid letting water run on the doors or inside the cabinets. If any spills occur, wipe them dry promptly.

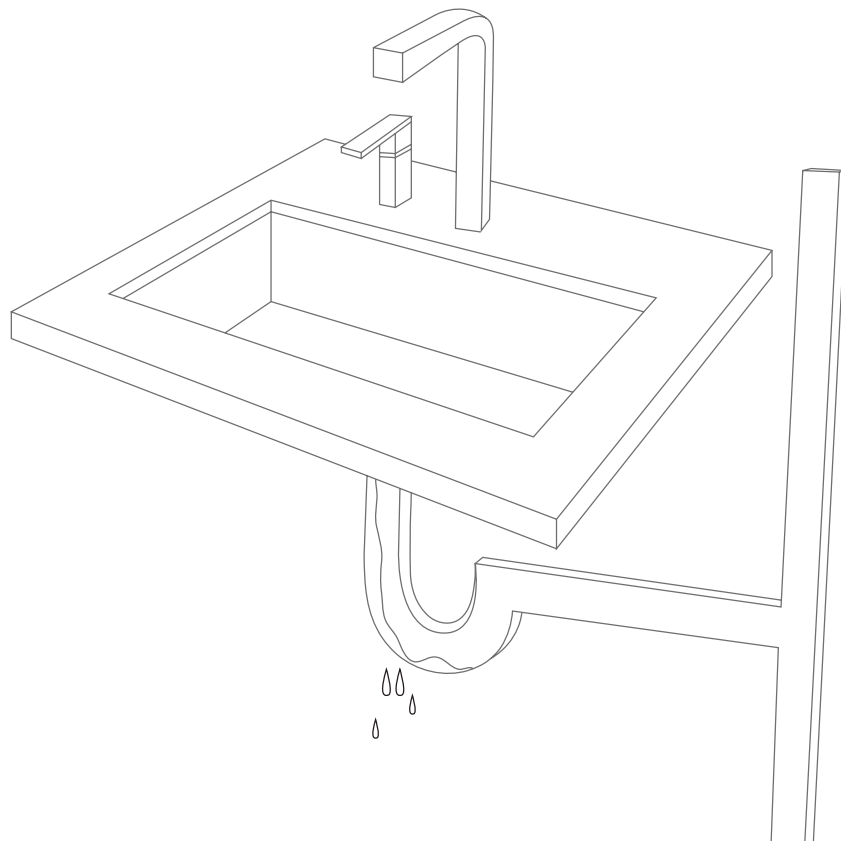

4. Promptly address any leaks inside the sink unit.

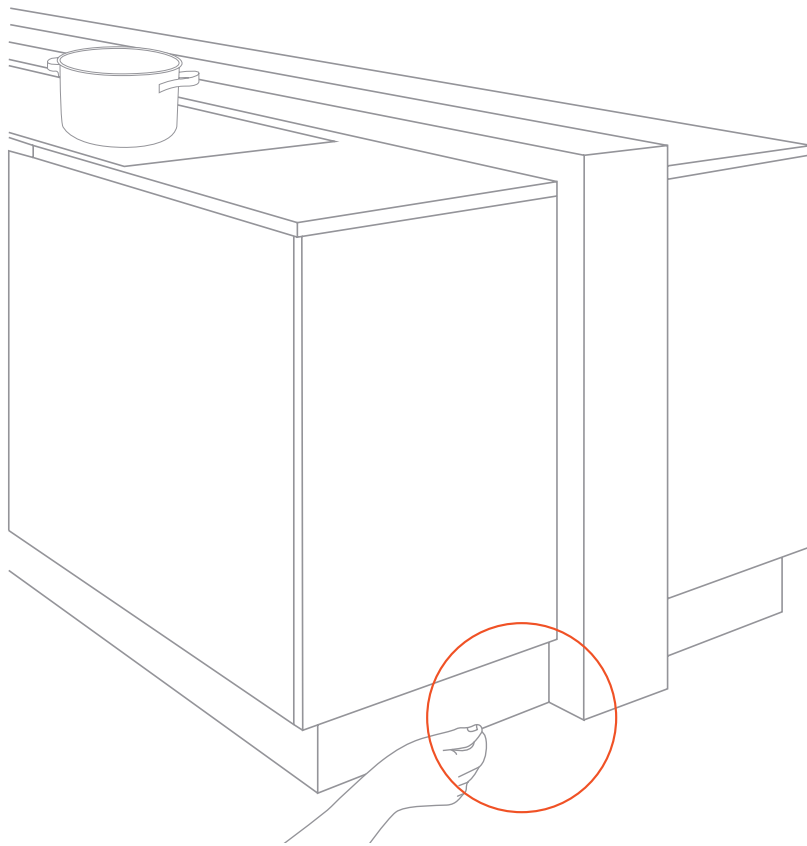

- 5.** When washing the floor, remove the skirting and replace it only after the floor is completely dry.



- 6.** Avoid putting weight on the doors or using them for support when getting up from the floor.

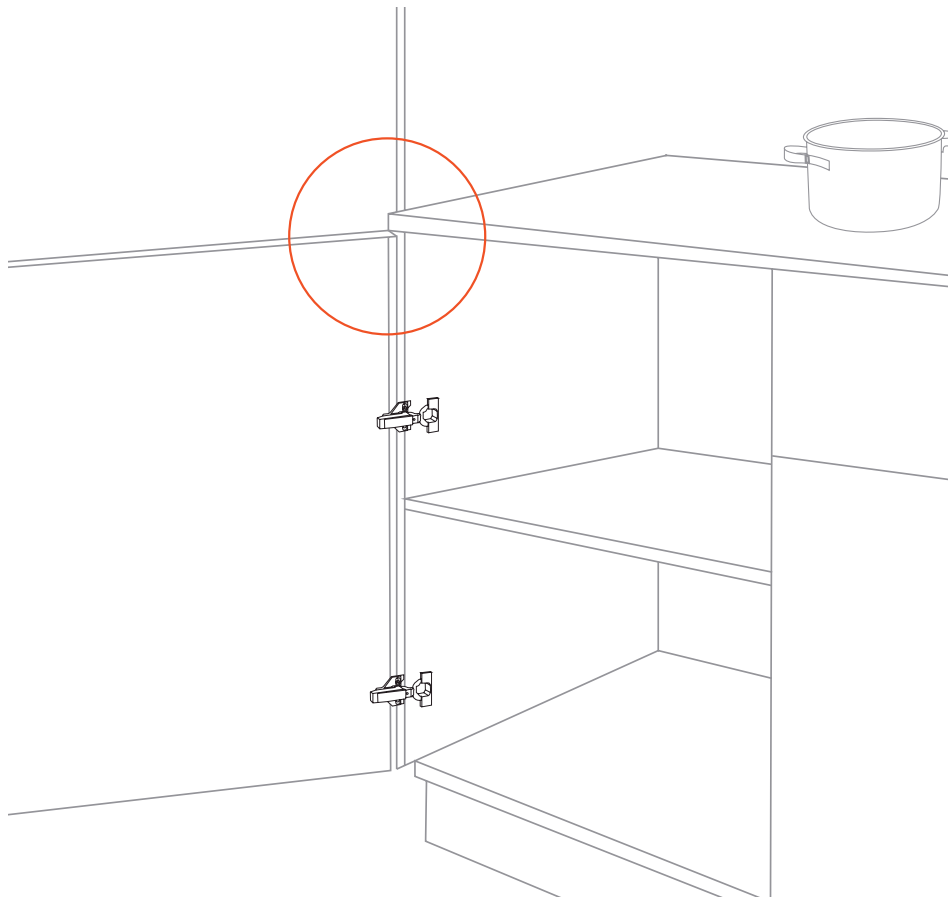

- 7.** Do not open units beyond the maximum opening radius specified by the hinge.

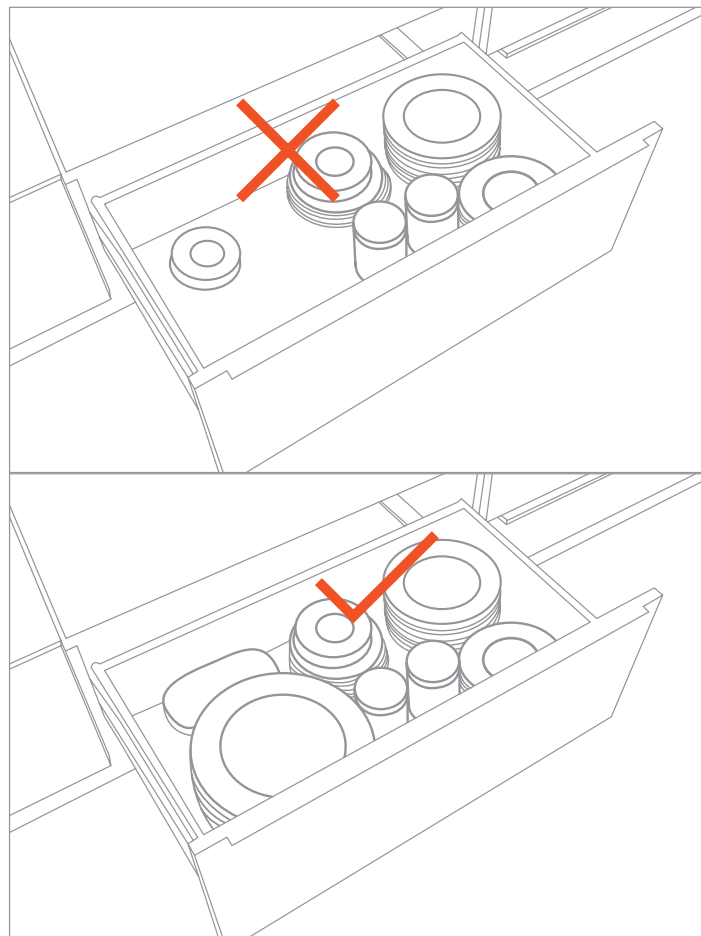

- 9.** Avoid placing heavy items unevenly on one side - distribute the weight evenly.

Küchen

kitchen | wardrobe | living

Contact Us

T: +65 6904 9612

Address:

1 Coleman Street #01-09/#02-08
The Adelphi Singapore 179803

Opening hours:

Mon-Sat: 10 am to 7 pm

Sun: 12 pm to 7 pm

Visit us at:

Kuchen.com.sg